

# CHEVY INSTALLATION INSTRUCTIONS

## 1. VALVE COVER INSTALLATION

- Remove existing valve covers from engine.
- Remove old gaskets and totally clean area ensuring smoothness.
- Carefully apply new gaskets. Make certain all holes line up. The use of gasket sealer is a good practice.
- Place new valve covers over the gaskets, once again make sure all holes line up and there is proper clearance.
- Insert and screw down valve cover bolts using washers. It is not necessary to crank these down extra hard since the gasket may become deformed. Use of hold down clamps, sold separately, is recommended.

## 2. WIRE LOOM INSTALLATION

- Install one wire loom on each valve cover.
- The wire loom should be mounted under the washer of the valve cover bolt.
- Slit the grommets as shown and place in looms.
- Press the wires into the grommets in the looms.



## 3. OIL BREATHER CAP AND PCV VALVE GROMMET

- When installing the oil breather cap make sure the beveled end is cut so the valve cover can "breathe" properly.
- The PCV valve grommet can be inserted in the opposite valve cover and the PCV valve placed in it.

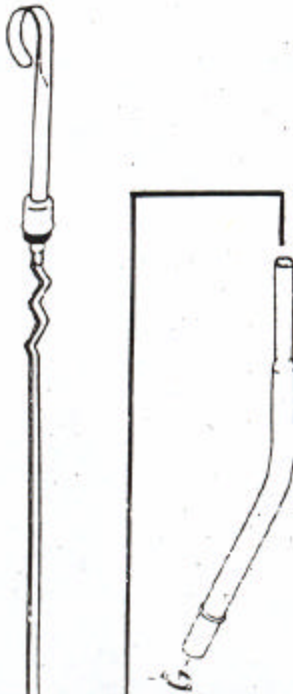
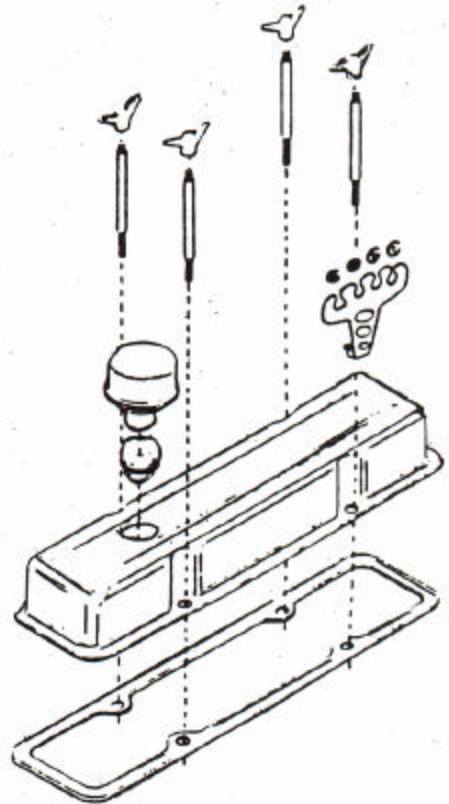

## 4. DIPSTICK INSTALLATION

- Take out old dipstick.
- Dipstick holder should now be pulled out. If removal is difficult try moving the holder back and forth while twisting and pulling.
- Clean hole where holder was removed and then install new one by pressing the holder completely into hole.
- Insert dipstick into holder.